

# HUBER+SUHNER® DATA SHEET

## SENCITY® ACCESSORY

### FOR SENCITY® SPOT-S ANTENNA

Rev: A



#### Down\_Sidetilt Bracket 9091.99.0225

Type no.	Article no.	Including
9091.99.0225	84061699	2 hose clamps for pole - dia. 25 to 85 mm

#### Mechanical & Environmental Properties

Material	STARFLAM
2002/95/EC (RoHS)	Compliant
Colour	RAL7042
Suitability	Indoor environment only
Dimensions	34.6 x 60 x 60 mm
Weight	0.03 Kg

Documents	
DOC-0000278984	security instruction (01.02.0777)

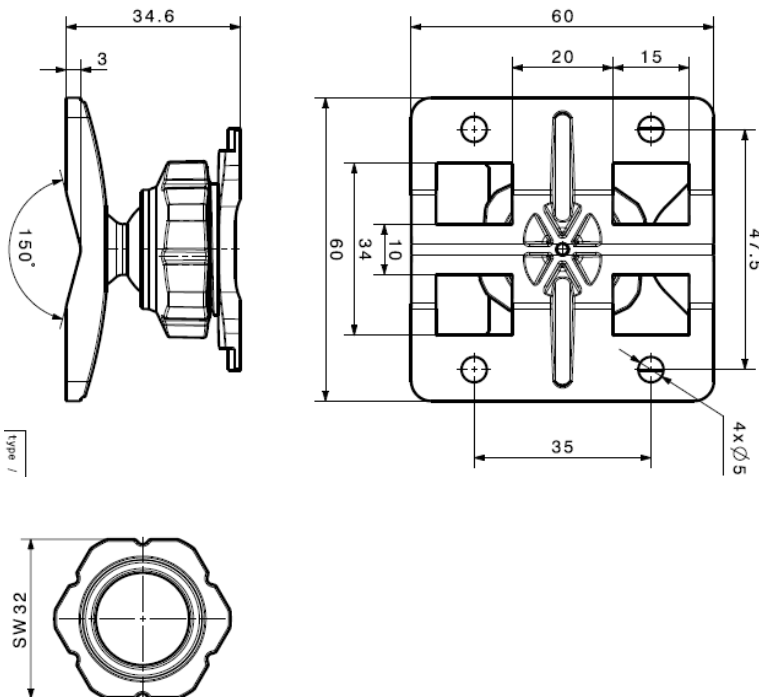

HUBER+SUHNER is certified according to ISO 9001 and ISO 14001

#### WAIVER!

It is exclusively in written agreements that we provide our customers with warrants and representations as to the technical specifications and/or the fitness for any particular purpose. The facts and figures contained herein are carefully compiled to the best of our knowledge, but they are intended for general informational purposes only.



**HUBER+SUHNER AG**  
**RF Industrial**  
**9100 Herisau, Switzerland**  
 Phone +41 (0)71 353 41 11  
 Fax +41 (0)71 353 45 90  
[www.hubersuhner.com](http://www.hubersuhner.com)

**HUBER+SUHNER – Excellence in Connectivity Solutions**